

Standard Construction and Materials

- FRAME:** 16-GA. galvanized steel, 6" wide, channel type.
- BLADE:** 18-GA. galvanized steel, "double-thickness". 1 1/8" thick with styrofoam insulation sandwiched between metal skins, mechanically fastened together. On 6" C-C standard spacing.
- AXLES:** 1/2" diameter plated steel stub.
- BEARINGS:** Oilite bronze.
- LINKAGE:** Concealed in channel, out of airstream.
- SEALS:** Blade and jambs of polyurethane.
- DRIVE SHAFTS:** 1/2" dia. plated steel, permanently extended 6" beyond frame for external drive. For internal drive, a blade clip will be provided. Please specify location of drive required.
- SCREEN:** (when indicated)
1/2" mesh, 19-GA. galvanized steel, .041"
- FINISH:** Mill.

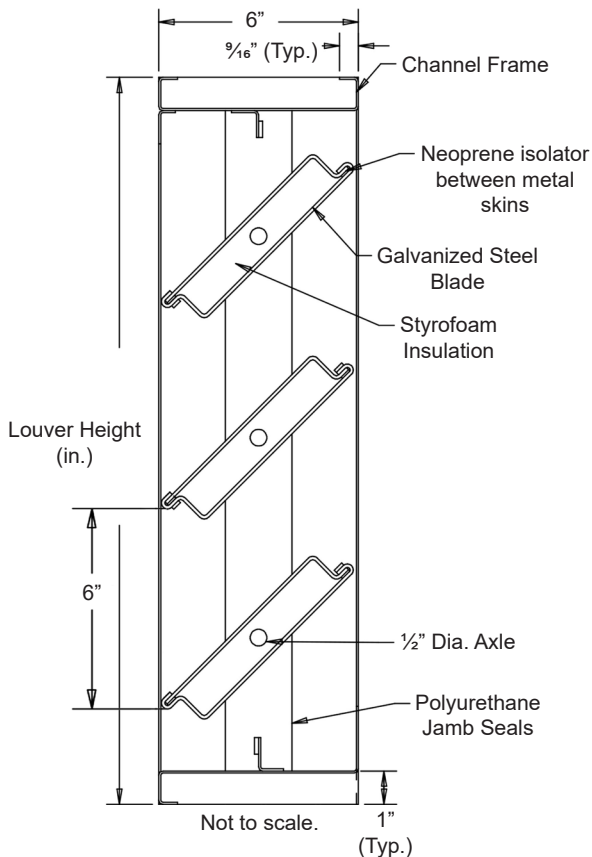

Options

- Flanged frames available.
- Frames and Blades available in other gauges and materials.
- Finishes - Enamels, Epoxies, etc.
- Seals - Stainless steel for jambs only.
- Other screens also available.

Notes

1. Louvers will be made to exact size required.
2. Please specify location of drive required.
3. Approximate shipping weight is 7.0 lbs./sq.ft.

Louver Sizes

Min Panel	Max Single Panel
10"W x 8 1/2"H	48"W x 72"H

Thermal Characteristics

Insulating factors for the standard blade construction:

R-Value: 4

U-Factor: .25 BTU per hour per sq. ft. per degree F.

The above values are based on calculations considering face area of the louver only. This does not include frames. Insulation of the louver frame shall be by others.

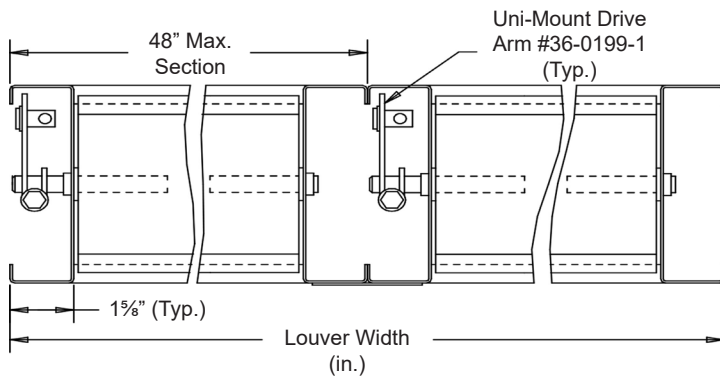

									
Item #	Qty	Width	Height	Width	Height	Mullion	Type	Location	
		Opening Size		Louver Size			Screens		Union Made
Arch. / Eng.:						EDR:		ECN:	Job:
Contractor:									
Project:				Date:		DWN:		DWG:	

In the interest of product development, Cesco Products reserves the right to make changes without notice.



450 Riverside Dr • Wyalusing PA, 18853
 Phone: 570-746-1888 • Fax: 570-746-9286
 www.cescoproducts.com